

LOVOL

MAKE WORLD BETTER

TECHNOLOGY CREATING THE FUTURE



LOVOL HEAVY INDUSTRY GROUP CO., LTD.

Address: No. 75, Huanghe East Road, Huangdao District, Qingdao City, Shandong Province, China.

Website: en.lovol.com

E-mail: lovol_overseas@global.lovol.com

TEL: +86-532-86907190

Facebook: Cons Lovol

As manufacturer, LOVOL has right to constantly upgrade and improve our products without informing to customers.
The pictures in literatures are for reference only, the detailed specifications are subject to real products.

Rated Power

11.5kW/2400rpm

Operating Weight

1810kg

Bucket Capacity

0.04m³

FR18E2-U
EXCAVATOR



RELIABILITY

Specialized Powerful Engine

Equipped with YANMAR Tier III engine with 11.5kW rated power which is specialized design for Mini Excavator, its powerful and low noise design is good for environment and healthy protection.

Core Components

All core components utilize first-class parts which are produced by world-renowned enterprises. Relying on Japan Engineering Center, LOVOL has established solid partnership with these enterprises and improved the quality and service life of these components. The supply of the core components like engine, pump, valve, motor, cylinder and so forth also can be priority guaranteed.

Key Structures

The boom adopts advanced box-hollow structure, high strength steel coordinating with cast steel frame with robot welding craft provide high reliability. The NM400 anti-wear steel are adopted on key positions of arm and bucket, the service life is about 30% longer than that of ordinary materials.

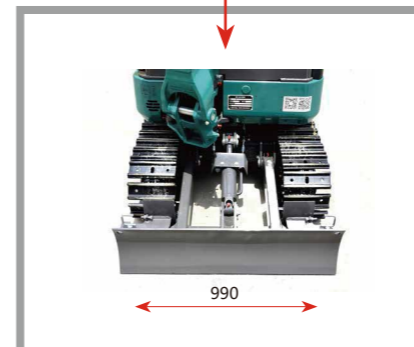
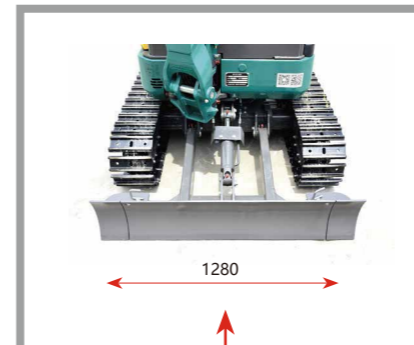

FLEXIBILITY

Compact Design

With the tailless design, the turning radius of machine tail is only 640mm. it is very suitable to work in narrow jobsite. The telescopic chassis, width-adjustable dozer blade and split dismountable cab make machine have good crossing ability.

Boom Swing

The working device could slip independently to left or right through the boom side-shift bracket, so that the machine does not need to be moved frequently when working in the narrow jobsite to do the boundary operation (such as wall root operation).

Inner-Hidden Design of Pipeline

The pipelines of working device and chassis are adopted inner-hidden design which could avoid scratch in narrow jobsite, and makes operation more flexible.

EFFICIENCY



Superb Match

The powerful engine is perfectly matched with outperformed hydraulic system, which could adjust output power according to the demand of working applications that reaches advanced operation performance simultaneously with operation comfort.

Advanced Hydraulic System

Arm, boom and rotary system adopt independent pump system, combining with exclusive main valve which achieving fast-soft and powerful operation.



Diverse Attachments

According to the application features of Mini Excavator, LOVOL can provide a package of solutions, besides standard configuration, the machine can also equip with rubber tracks, trenching buckets, hammers, auger, quick coupler and forth, these specialized devices could significantly improve the operation efficiency.

COMFORT



Cab

The cab is the TOPS\FOPS compliant with safety belt, which makes the operation safer. The luxurious seat with armrest and headrest can reduce the operation fatigue dramatically. The lengthened joy stick lever makes operator feel more convenient to operate machine.

Low Noise Design

Adopts advanced design to reduce the noise making operation more comfortable, the YANMAR engine has good features of low noise and vibration.

Rotating Lock Pin

In some special working conditions, the rotating function is locked for operation safety.

INCREASE YOUR PRODUCTIVITY AND PROFIT WITH LOVOL ATTACHMENTS

You can easily expand the performance of your machine by utilizing any of the variety of LOVOL Attachments.

Each LOVOL Attachments is designed to fit the weight and horsepower of LOVOL Excavator for improved performance, safety, and stability.



STANDARD CONFIGURATION

Telescopic chassis	LED working light
Start the engine with safety bar locked	Auxiliary pipeline
Split dismountable cab	230mm steel track
Safety belt	Pilot energy accumulator
12V Power battery	Transfer pump
Hand rest	Seat(including back extension)
Toolbox	Rotary locking pin
Glove compartment	
400mm Standard bucket	

PRODUCT SUPPORT NETWORK

Lovol heavy industry group has established a complete service network covering more than 50 countries in Asia-Pacific- Africa. South America and Russia etc., so as to provide better services for global customers.

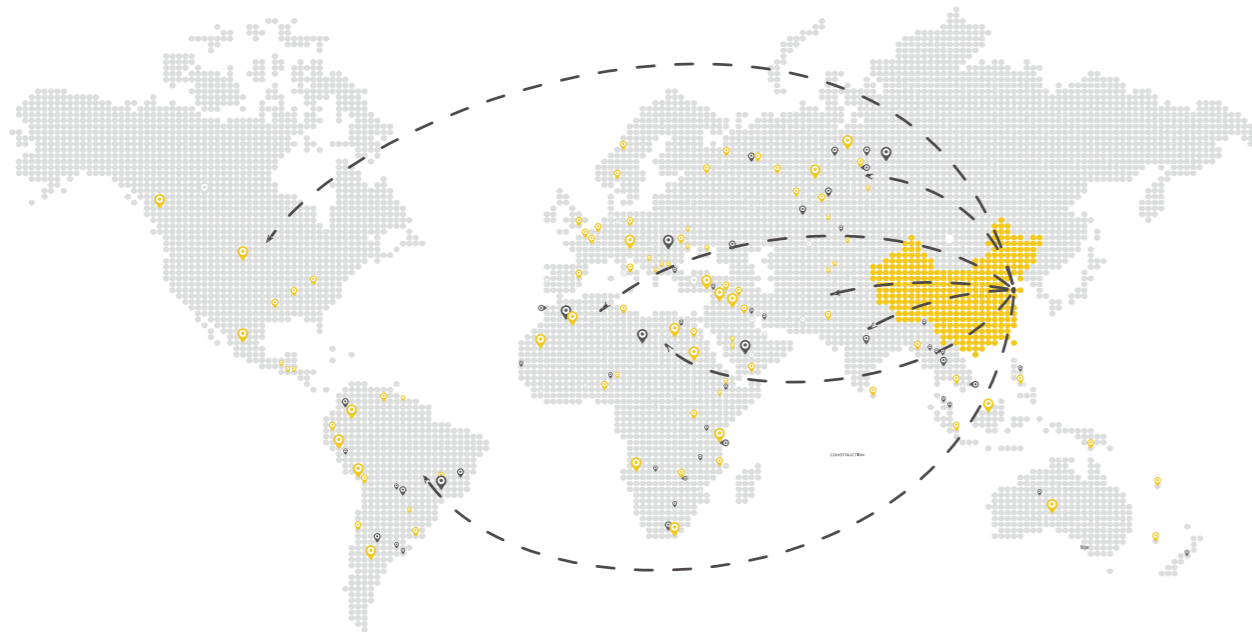

TECHNICAL SPECIFICATIONS

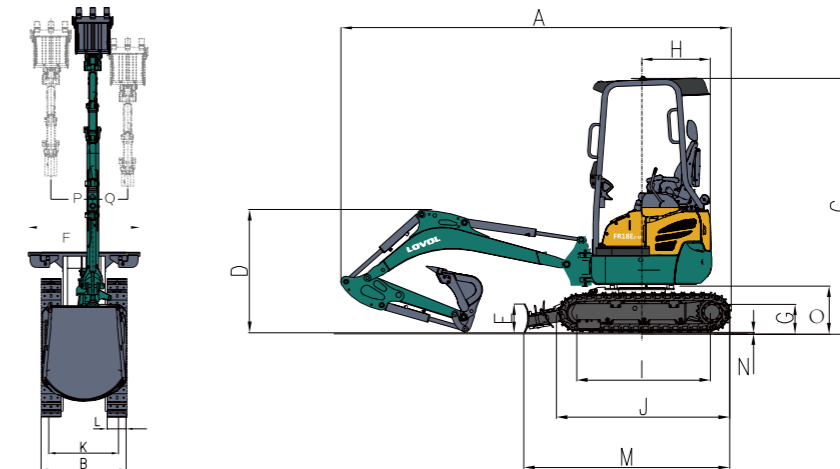

Dimensions

Dozer Blade Lifting Height	X	260mm
Dozer Blade Falling Height	Y	180mm
Min. Turning Radius	Z	1443mm

Dimensions

Shipping Length	A	3575mm
Shipping Width	B	990mm
Shipping Height	C	2347mm
Working Device Height	D	1120mm
Dozer Blade Height	E	262mm
Dozer Blade Length	F	990/1280mm
Min. Ground Clearance	G	153.5mm
Tail Turning Radius	H	640mm
Length to Center of Rollers	I	1230mm
Track Length	J	1590mm
Track Gauge	K	760/1050mm
Track Shoe Width	L	230mm
Shipping Ground Length	M	1895mm
Grouser Height	N	16.5mm
Ground Clearance of Counter Weight	O	438mm
Working Device Left Offset Distance	P	480mm
Working Device Right Offset Distance	Q	400mm
Max. Digging Height	R	3540mm
Max. Dumping Height	S	2440mm
Max. Digging Depth	T	2310mm
Max. Vertical Digging Depth	U	1910mm
Max. Digging Radius	V	3905mm
Max. Ground Digging Radius	W	3845mm

