

FL958K Wheel Loader Specifications

LOVOL

FL958K Dimensions

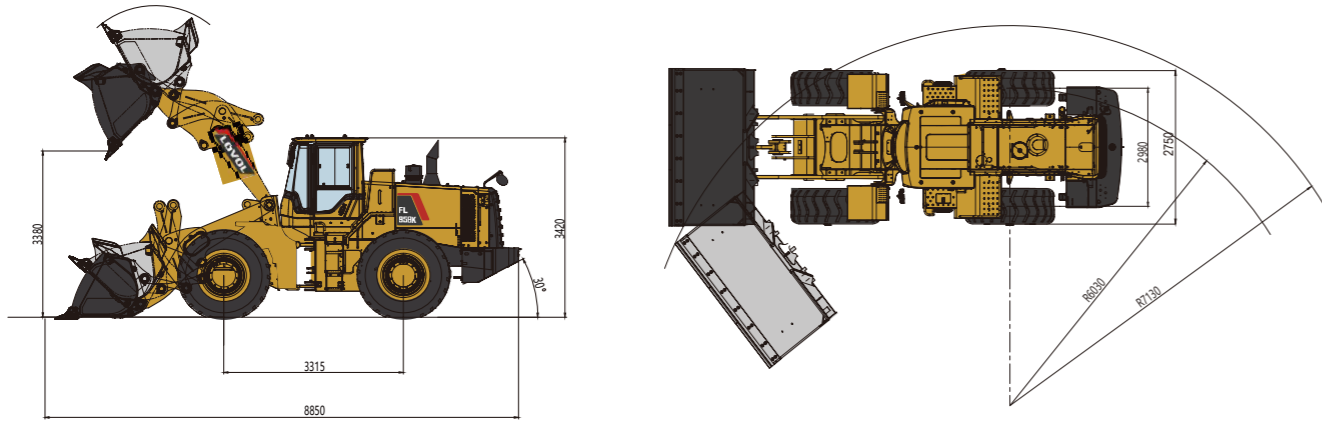

Item	Specifications
Rated Load	5500kg
Max. Traction Force	165kN/160kN
Max. Gradeability	30°
Max. Dump Clearance	3380mm
Dump Reach	1140mm
Wheel Tread	2150mm
Wheelbase	3315mm
Overall Dimension (L×W×H)	8850mm×2980mm×3420mm
Width Over Tyres	2750mm

Engine	
Emission Standard	Stage III
Number of Cylinder	6
Max. Torque	1150/1187N·m
Rated Speed	2000/2200rpm
Displacement	9.7/9.3L

Transmission System	
Torque Converter	/
Modulus of Converter	4±0.2
Transmission	Full-automatic shift planetary style
Gear Shift	2 forward, 1 reverse
Max. Speed	42km/h

Front and Rear Axles	
Axles Type	Dry

Tyre	
Tyre Size	23.5-25
Ply	Front 18, rear 16
Front Tyre Pressure	0.35-0.375Mpa
Rear Tyre Pressure	0.28-0.3Mpa

Steering System	
Type	Flow amplification steering system
Steering Angle Each Direction	37°
Min. Turning Radius	6030mm

Hydraulic System	
Working Pressure	19Mpa/18Map
Boom Lifting Time	5.7s
Total Cycle Time	10.6s

Brake System	
Full hydraulic braking system	

Service Refill Capacity	
Fuel Tank	320L
Hydraulic Tank	210L



LOVOL HEAVY INDUSTRY GROUP CO., LTD.

Address: No. 75, Huanghe East Road, Huangdao District, Qingdao City, Shandong Province, China.

Website: en.wlovol.com Alibaba: lovolconstruction.en.alibaba.com Facebook: Cons Lovol

E-mail: lovol_overseas@global.lovol.com TEL: +86-532-86907190

As manufacturer, LOVOL has right to constantly upgrade and improve our products without informing to customers. The pictures in literatures are for reference only, the detailed specifications are subject to real products.

Engine Model	WEICHAH WP10G231E343/CUMMINS QSL9.3
Rated Power	170kW/168kW
Operating Weight	18000kg/17970kg
Bucket Capacity	3.3m³
Max. Breakout Force	175kN/160kN

FL958K

WHEEL LOADER