

TECHNICAL SPECIFICATIONS



Engine

Engine Model	CUMMINS QSM11
Number of Cylinders	6
Max. Torque/Speed	1898N·m/1400rpm
Displacement	10.8L



Hydraulic system

Max. Main Pump Flow	760L/min
Main Safety Valve Pressure	34.3MPa



Main Performance

Bucket Digging Force	310kN
Arm Digging Force	260kN
Max. Traction Force	382kN
Max. Walking Speed	4.6km/h
Min. Walking Speed	2.9km/h
Rotary Speed	7.8r/min
Gradeability	35°
Ground Pressure	83kPa



Oil Capacity

Fuel Tank	670L
Hydraulic Tank	370L
Engine Oil	38L



LOVOL CONSTRUCTION MACHINERY GROUP CO., LTD.

Address: No. 75, Huanghe East Road, Huangdao District, Qingdao City, Shandong Province, China.
 Website: en.lovol.com Alibaba: lovolconstruction.en.alibaba.com Facebook: Cons Lovol
 E-mail: lovol_overseas@global.lovol.com TEL: +86-532-86907190

As manufacturer, LOVOL has right to constantly upgrade and improve our products without informing to customers.
 The pictures in literatures are for reference only, the detailed specifications are subject to real products.

Rated Power **298kW/2000rpm**
 Operating Weight **49000kg**
 Bucket Capacity **3.0m³**

FR510E2-HD
 EXCAVATOR



RELIABILITY

Advanced Technology

First-user of function-relief cushion valve system in industry, machine's respond could keep the same speed even in the extreme cold weather. On the premise of keeping the optimal impact pressure, the starting or switching of working device without any postpone, that makes smooth, efficient and energy-saving operation of machine and reaches to leading level of industry.

Powerful Engine

The new generation of CUMMINS QSM11 engine originally imported from America which is specially designed for mining applications. Its exclusive PT fuel control and injection technology delivers higher precise and full efficient traits compared to traditional electric controlled high-pressure common rail technology.

Electric Control Positive Flow System

During the design stage, LOVOL has utilized the latest technologies to develop an integrated hydraulic system. The positive flow control system adjusts the displacement of pump and the motion of valve spool simultaneously, delivering optimal operating experience for the operator with smooth and responsive control.

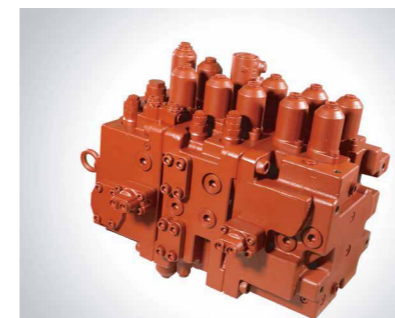

PRODUCTIVITY

Superb Match

Each component in powertrain system, such as engine, gear, rotary motor, working pumps and hydraulic cylinder are specially customized to achieve perfect match with one another, the whole system features are more reliable.

Great Digging Force

On the premise of ensuring static digging force, LOVOL dedicate to research of dynamic digging force. The system will automatically detect the pressure when face big frustration during digging, and automatically adjust output pressure to keep the powerful force in digging process.

Larger Bucket

Equipped with larger bucket which is specially designed to achieve maximum productivity and durability. The unique shape design improves the bucket's stability when doing loading job. Applying with latest technology and optimal hydraulic system, it has good performance on fuel consumption.

ROBUSTNESS



Rigorous Test and Experiment

Machine test: LOVOL CL-6 machine testing yard covers more than 200,000 square meters, it can simulate various applications like earthmoving, aggregate, sand, quarry and forth. The test including strengthen vibration, noise, working efficiency, oil consumption, travel and climbing tests, etc. Every new model should go through more than 2,000 working hours strengthen combination test here.

Robust Chassis

Reinforcement of Track Roller, Carrier Roller, Idler, Drive Roller and Track makes brace capacity increase dramatically which can also working in the temperature of -45 C. The crawl tracks are made of high-strength anti-wear steel, with great grip on ground.

Reinforced Working Device

Adopts high-strength rock bucket teeth which is special suitable for the tough applications, the boom and arm are reinforced to prolong the service life. Self-lubrication shaft sleeve is used to make every linkage works smoothly with high durability.

COMFORT

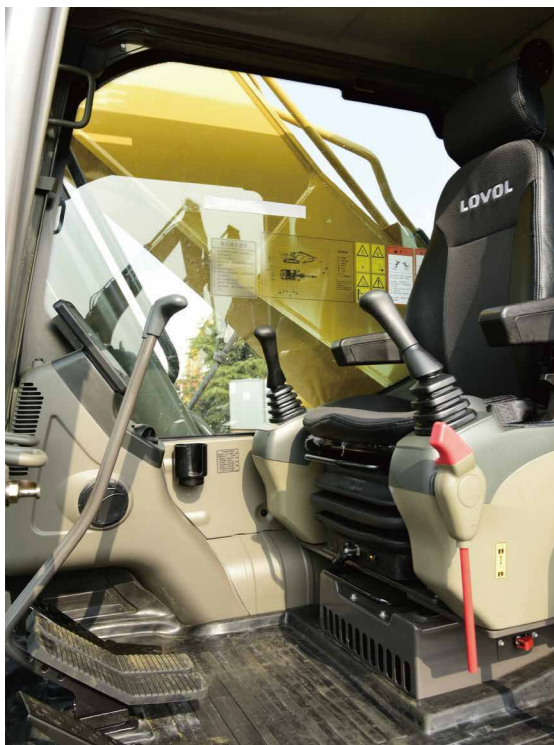

Large Spacious Cab

Equipped with spacious cab which provides operator large space to operate machine. The premium suspension seat with armrests is very comfortable and it can reduce the working fatigue dramatically. Front windshield can be partially or fully retracted to the cab roof. Rearview camera is optional to get better rear vision in order to improve operation safety in jobsite.

Ergonomic Design

The proportional joystick delivers sensitivity, accuracy and smoothness during operation. This joystick is specially designed to meet different operating conditions. Intelligent control system is standard which could control diverse attachments such as bucket, hammer, scarifier and hydraulic scissors.

Low Noise and Low Vibration

In order to reduce work fatigue and improve productivity, the noise inside of cab has been controlled to the lowest level. The cab is attached to the frame with buffer that dampens vibrations and sound levels to enhance operator comfort.

INCREASE YOUR PRODUCTIVITY AND PROFIT WITH LOVOL ATTACHMENTS

You can easily expand the performance of your machine by utilizing any of the variety of LOVOL Attachments. Each LOVOL Attachments is designed to fit the weight and horsepower of LOVOL Excavator for improved performance, safety, and stability.



Hydraulic Hammer



Scarifier



Standard Bucket



STANDARD CONFIGURATION

Engine

- Turbocharged, 6-cylinders, water-cooling, direct injection
- Radiator with protective fence
- Oil bath type cleaner
- Air intake heater
- Fan guard
- Double filters, dry air filter
- Engine oil pan with oil drain valve
- Automatic idle speed system
- Three-stage fuel filter
- 75A/24V alternator

Cab

- Ashtray
- Cigarette lighter
- Seat belt
- Shade plate
- Storage compartment
- Emergency hammer
- Air conditioner
- Audio speaker
- Shock absorber
- Flexible aerial
- Radio
- Hydraulic safety locking rod
- Sun proof safety glass
- Cab floor mat
- Pull-up front window
- Dismountable lower windshield
- Sun shade window
- Windshield wiper
- Skylight window
- Suspended seat
- Big storage area

Chassis

- Fixed chassis
- 600mm double tooth track plate

Hydraulic System

- Automatic hydraulic system (flow confluence system)
- Multistage filtration system
- Anti-sway valve
- Boom and stick locking valve
- Cylinder buffer device
- Anti-slope turning device
- Waste oil drainage pipeline
- Pilot buffer valve (rotary, stick, boom)
- Dual-speed travel motor
- Hydraulic hammer pipeline

Electronic Control System

- 24V power battery
- Monitor brightness adjustment
- Maintenance tips
- Safe stop & start function
- Master switch
- Engine start protection
- Multilingual display
- Cab ceiling light
- Diagnostic interface
- Emergency stop switch
- Automatic diagnosis system
- Automatic idle speed system
- One-touch pressure enhancement
- Anti-theft system

Swing Platform

- Toolbox
- Large pedal
- Large handrail
- Bottom guard plate
- Anti-crash beams
- Anti-skid plates
- Passage with handrails

TECHNICAL SPECIFICATIONS

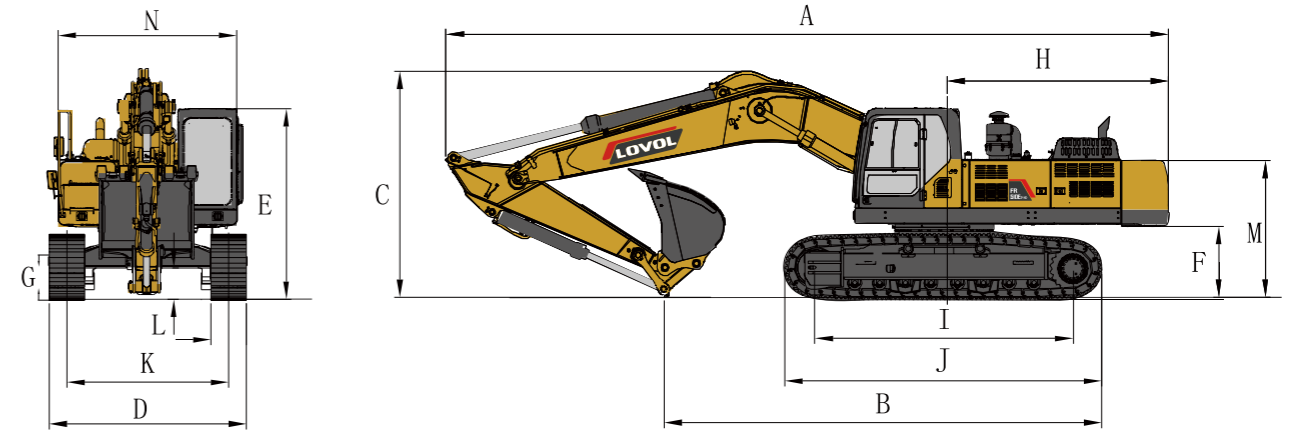

Working Range

Max. Digging Height	1	10620mm
Max. Dumping Height	2	7443mm
Max. Digging Depth	3	7282mm
Max. Vertical Digging Depth	4	6220mm
Max. Digging Radius	5	11520mm
Max. Ground Digging Radius	6	11306mm
Min. Turning Radius	7	4962mm

Dimensions

Shipping Length	A	12253mm
Shipping Ground Length	B	7398mm
Boom Height	C	3900mm
Shipping Width	D	3340mm
Cab Height	E	3900mm
Ground Clearance of Counter Weight	F	1237mm
Min. Ground Clearance	G	550mm
Tail Turning Radius	H	3800mm
Length to Center of Rollers	I	4370mm
Track Length	J	5357mm
Track Gauge	K	2740mm
Track Shoe Width	L	600mm
Hood Height	M	2348mm
Rotary Platform Width	N	3340mm

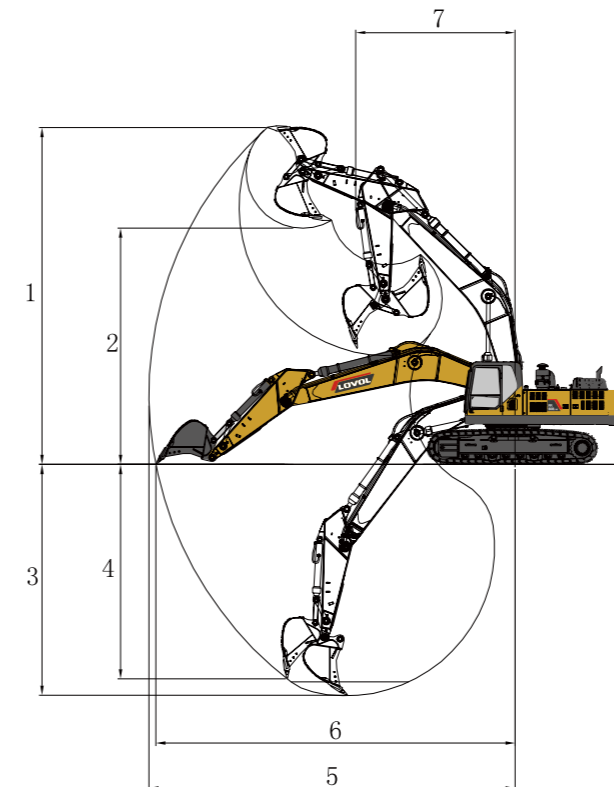

Other Specifications

Boom Length	7060mm
Arm Length	2900mm
Track Section Number (each side)	49
Track Roller Number	9